

ididit's Key to Keyless Ignition System Owner & Installation Manual



www.ididitinc.com

*Deluxe
Kit*

What's inside this installation booklet:

1. System Overview
2. System Operation & Components
3. System Installation & Reference Diagrams

ididit is...

Your Steering Column Specialist

ididit inc. 610 S. Maumee St. Tecumseh, MI 49286

PH: 517-424-0577 FAX: 517-424-7293

Revised 4/15/2011

Congratulations on your purchase of ididit's Key to Keyless - Intelligent Push Button Start system!!

Your Key to Keyless - Intelligent Push Button Start completely eliminates your vehicles ignition switch and lets you securely operate your vehicle with just the push of a button!

Simply carry one of the systems digital RFID Key Fobs with you. As you come into proximity of your vehicle, Your Key to Keyless verifies your identity, pre-authorizes your ignition and with just the "Push of a Button" you're engine roars to life!

Pieces included in this kit:

- A.) Ignition Control Module (ICM)
- B.) Start Button w/LED & Gasket
- C.) Power Harnesses
- D.) Programming Switch
- E.) Key Fobs



Information in this manual is divided into three sections:

1. System Overview
2. System Operation & Components
3. System Installation & Reference Diagrams

SYSTEM OVERVIEW:

Your Key to Keyless Intelligent Push Button Start system consists of: Ignition Control Module (ICM), Start Button with LED & Gasket, three Power Harnesses & one Programming Switch and two system Key Fob Transmitters.

The systems **Key Fob** is a motion activated RFID device that automatically communicates with the Ignition Control Module as you move within proximity of your vehicle, (Typically about 10 feet). Each Key Fob is completely unique with over 6 billion different codes. A single Key Fob can be programmed into multiple vehicles allowing its user to operate all his / her vehicles, motorcycles, boats or other toys by carrying just one Key Fob

The **Ignition Control Module (ICM)** provides two functions, it communicates with the system Key Fob(s) and provides switching operations for your Ignition, Accessory and Starter circuits.

Basic installation consists of; mounting and connecting the Start Button, mounting the ICM under your dash. Connecting the 3 or 4 wires from your vehicles Ignition switch to the ICM along with any Accessory Harness connections appropriate for your particular installation. Then lastly, testing your system.

❑ **New Ignition Installations:**

On a fresh build where you are installing all your wiring from scratch, installation is as easy as wiring in a traditional Ignition switch. Generous harness lengths allow for great freedom of choice of module and Start button placement. Your **Key to Keyless Intelligent Push Button Start** even lets you choose how you would like to configure the systems operation. *See *Installation Diagrams*

❑ **Custom, Hotrod or Vintage vehicles:**

The **Key to Keyless Intelligent Push Button Start** adds an elegant touch of technology to any vehicle. Our advanced and versatile design using only professionally quality components lets your **Key to Keyless** fit right into the most elite vehicles. Straight forward easy to understand directions make replacing a traditional Ignition key system an afternoon's project.

❑ **Newer Vehicle:** *(with a locking steering column or security "chip" keys)*

Rather than connecting every wire of a modern ignition switch, the **Key to Keyless Intelligent Push Button Start** can be installed as an "**Ignition Switch Controller**" on most newer vehicles. This simple **two wire** installation allows your **Key to Keyless** to control all ignition operations through the existing switch. It completely eliminates any need to use a key to start your vehicle, while leaving the existing locking steering column or manufacturer security key systems in place. *See "*Newer Vehicle Discussion*" (pg 10) and "*EZ Installation*" (pg 15).

SYSTEM OPERATION:

Operating your **KEY TO KEYLESS** is designed to be absolutely effortless. When you approach your vehicle, the system, upon reading your valid Key FOB will pre-authorize your vehicles ignition system to start.

TO START:

Place your foot on the Brake, then depress of the Start Button and your starter will begin to "crank" and continue until the button is released. The Start Button LED will glow while your vehicle is running.

TO STOP YOUR ENGINE:

Place your foot on the Brake, Push and HOLD the Start Button for 2 seconds and your engine will shut off.

THE START BUTTON:

Generally mounted in the vehicle dash or center console, the “Start Button” provides one touch operation of your vehicles ignition system. Designed to mimic a natural “*starting feel*”. The starter will continue to crank as long as the Start Button is depressed. If you fail to start your vehicle during the first crank you may need to push the start button twice to re-initiate the “Crank” mode.



(Illuminated Push Button installed in ididit's Tilt Column)

THE IGNITION CONTROL MODULE (ICM):

IMPORTANT Always mount the ICM inside of your vehicle, **DO NOT** mount in the engine compartment!

The KEY TO KEYLESS ICM provides two functions. It contains the systems receiver and reader components that handle communication between your vehicle and the Key FOB. Secondly, the **ICM** houses a group of high current 60 AMP Relays that provide all switching operations for the Ignition, Accessory and Starter circuits. By bringing all the system relays on board **KEY TO KEYLESS** eliminates the “*spaghetti look*” of hand wiring multiple external relays.



(ididit's ICM)

All wires are professionally terminated using Molex® high current connectors that plug and lock securely to the ICM. Independent switching of accessories allows **KEY TO KEYLESS** to be configured in several different ways: One Accessory circuit can be turned **OFF** during starter “crank” to reduce battery load while your Ignition circuit stays **ON**.

THE KEY FOB:

Key Fobs represent the latest innovation in security technology. Each Key Fob is completely unique, with over 6 billion different code combinations. Fob's can be switched to operate in either **Automatic** or **Manual** modes giving you complete control of how and when the system arms and disarms. Key Fobs have 3 adjustable range level settings and include a two stage low battery indicator.



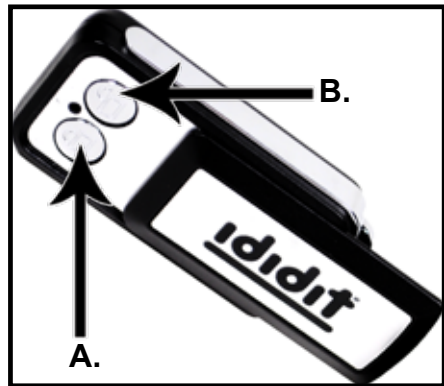

Four Independent Feature Control Channels:

Each of the Key FOBs hidden buttons is able to operate two individual feature channels by sensing the difference between a "Short Push" or a "Long Push". These four independent selectable feature channels are user programmable so they can be used for virtually any option such as Remote Keyless Entry, Shaved Door "Pop" (*single / dual*), Remote Trunk release, Automatic Window Roll up, Lighting or Video activation or whatever else you can dream up.



(Key Fob)

- A.) Button #1 (): Short Push = Lock Long Push = Trunk Release**
B.) Button #2 (): Short Push = Unlock Long Push = Radio, etc...

Being able to select whether the Key FOB operates in Manual or Automatic mode allows you to control what features YOU want to operate at a car show while still keeping your vehicle completely protected.

Key FOBs are powered by an easily replaceable extended life lithium battery that typically lasts one year. Up to 5 unique Key FOBs can be programmed into each system, additionally a single Key FOB can be programmed into multiple vehicles allowing its user to operate all his / her vehicles, motorcycles, boats or other toys by carrying just one Key FOB. Ruggedly made from high impact material, Key FOBs reliably perform first time every time.

Key FOB Batteries:

Key FOBs are powered by long life CR2030 Lithium disk battery that provides a typical life of 1 year+. Battery replacement is simple and replacement batteries are available at most drug stores.

MANUAL & AUTOMATIC MODES:

The **KEY TO KEYLESS Intelligent Push Button Start** has two modes of operation “**Manual**” and “**Automatic**”.



In “**Automatic**” mode the functions of Enabling or Disabling your ignition occur without any action on your part, other than having the Key FOB present.

In “**Manual**” mode the Key FOB button must be pushed to transmit the code to disarm the system.

Manual operation may be desirable at various times, initially during installation and set up, (*because it allows you to specifically test operation without Key FOB range being a factor*). Secondly, you may want to put the system into Manual mode at times when you are near your vehicle but do not want the system to disarm, such as at a car show. Changing between modes is accomplished through a simple sequence of pushes of the Key FOB button.

The Key FOB LED provides visual status of which “**mode**” the system is in: “**Manual**” or “**Automatic**”

Note: Key FOBs are shipped in Manual mode.

You will want to keep your Key FOBs in manual mode until you have completed your system installation. Once you have completed initial system testing, you will switch your Key FOBs into “Automatic” mode for final testing and be able to use your system in a “Hands Free” manner.

If you purchased a “Spare” Key FOB and plan to store it as a back up, storing it in Manual mode will preserve battery life.

To “Check” which mode you are in Manual or Automatic:

1. Simultaneously push and hold BOTH the buttons on the Key FOB until the LED goes OUT. (*Approximately 6 seconds*)
2. When you release the buttons the Key FOB will tell you what mode it is in by flashing either 3 or 5 times.

3 Flashes = Automatic Mode

5 Flashes = Manual Mode

To “Change” from Manual mode to Automatic mode:

Repeat the same sequence as you did to check the mode, **BUT** after the Key FOB finishes its “3 or 5 Flash Back” **QUICKLY** push both buttons again and look for the LED to “**Flicker**”. The flicker will confirm the mode has been changed. Modes toggle from Manual to Auto then back again. If you are ever unsure if you completed a mode change you can always do a “mode check”.

KEY FOB LEARNING MODE:

The KEY TO KEYLESS has the ability to learn up to 5 unique Key FOB Tags. Should you ever want to add an additional Key FOB for a spare or replacement, you can use the following instructions to program a new FOB(s) into your system.

***** Note: If you have lost all FOBs to your system and need to add a replacement FOB, you will need to gain access to the system by first using the “Emergency Bypass” sequence, then proceed into “FOB Learning Mode”**

To enter “Key FOB Learning Mode”, first put system in **Accessory Mode** by pressing the start button one time without putting your foot on the brake.

Once in Accessory Mode, put your foot on the brake and continually hold it down.

Next, press the programming Button 10 times. The LED should begin flashing fast then turn ON solid.

Next, (Within 5 seconds) push and hold down the **Lock button** of the 1st Key FOB you wish to program into the systems. The Start Button LED will flashes 3 times indicating the Key FOB has been learned.

Once you see the 3 flashes you can add additional Key FOBs using the same method up to a total of 5 Key FOBs per system. When you have add all Key FOBs you wish to add to the system, Simply wait, and the system will automatically exit Key FOB Learning mode 5 seconds after your last Key FOB was added to the system. The LED will again begin a long flashing fast sequence indicating the system has exited Programming Mode. Just cycle out of Accessory mode to return to Armed mode to return to normal operation.

THE PROGRAMMING BUTTON:

The systems “Programming Button” plugs into the side of the ICM.

The Programming Button serves several functions. It is used to enter Feature Select Mode and customize feature operation for your individual vehicle. It is also used if you were to ever want to add or replace additional Key FOBs into your system. In the unfortunate event that you were to lose your Key FOB and were without a spare, you would be able to start your vehicle by using the Programming Button to enter your unique PIN# into the system. This PIN # can be found on your system “**Owners Card**”.



You may choose to install the Programming Switch as part of your system installation or store the Programming switch in a secure location, such as your trunk until such time it may be needed.

Owners Card for Emergency Bypass:

Included in your **KEY TO KEYLESS- Intelligent Push Button Start** system is an “**Owners Card**” with your systems unique 4 digit **PIN#**. This number should be kept with you whenever you drive. The PIN # on the card is entered into the system via the Programming Button to bypass the system in the event of a lost Key FOB.



EMERGENCY BYPASS MODE:

So that you are never let stranded unable to start your vehicle, The KEY TO KEYLESS has an "Emergency Bypass" Mode which will allow you to start your vehicle by using a unique PIN# that can be found on the "Emergency Bypass Card" that came with your system. This is an important number to keep with you so put the card in your wallet or write the number down where you can find it if needed.

To enter emergency Bypass Mode, when the system is ARMED, simply depress and hold down the brake, then push the systems Programming Button 10 times, The LED will begin flashing fast.

Next, Using the 4 digit PIN# from your Owner Card. Enter the first number by pushing the Programming Button the number of times equal to the first PIN number. **EXAMPLE: if your PIN# 5 - 4 - 3 - 2**, While the LED is flashing fast, you would begin by pushing the Programming Button "5X" then stop, The LED will go OFF for 1 second after each number has been entered indicating it has accepted the first number,

Next, enter then 2nd number of your PIN in the same manner, followed by the 3rd and finally the 4th number. After the final PIN# has been added, (If it is correct) the LED will turn ON solid indicating the system has been bypassed and is ready to start.

Just take your foot off the brake, then depress the brake again and you can Start the vehicle.

NEW VEHICLE INSTALLATION:

When installing on a newer vehicle there are some factors to consider before starting your installation.

- ▶ **Do you have a “Locking” steering column?**
- ▶ **Do you have a “Chip in the key”**
- ▶ **Where to access the ignition switch wires?**

▶ **Do you have a “Locking” steering column?**

For almost 30 years now vehicles have had one or another type of “Locking Steering Column” system. These range in design from mechanical to electronic, simple to complex and can be *easy as pie* to *harder than # @ *!* to remove. An initial consideration as to your installation is what you plan to do with it if you have a locking steering column.

▶ **There are a couple of approaches.**

First, if you are mechanical and feel up to the work, these column locks can be removed. One of the best sources for information for any vehicle is a qualified body shop. They remove and replace column locks frequently as a matter of repairing attempted auto thefts.

▶ **If you are less inclined, don't worry there are other options.**

One popular option is the **EZ Installation**. This method sacrifices an existing key to have its “head cut off” By doing so, the cut key can be left in the ignition switch. With the switch turned to the ON position, the steering column remains unlocked. Many switches can be easily hidden with a cap or cover.

*** See *EZ Installation*

▶ **Does your vehicle have a security chip in the key ?**

Many newer vehicles also have some type of “chip in the key” as part of a factory security system. If your vehicle has one of these systems this will need to be addressed for the **KEY TO KEYLESS** to work correctly. There are several ways this type of installation can be approached. Either by removing the keys “Chip” and attaching it behind the ignition switch so the factory system still reads it, or by purchasing a “Factory Security Bypass Module” . These are available from through most vehicle alarm distributors or shops. They are commonly used when installing a remote start system. They wire into the factory system and automatically give the factory system the code it needs to deactivate.

► **Determining what type of chip in the key do you have?**

There are two basic types; one has the “Chip” in the head of the key, (Toyota, Ford and Chrysler to name a few) and the other type which has the chip in the keys shaft (*this looks like a black dot in the key shaft and was popular in older GM vehicles*) If you are leaving a “Cut key” in the lock, and you have the chip in the keys shaft, there’s nothing more to do; since the chip remains in the lock. On the other hand if you have the *chip in the head of your key* and must cut off the head of the key, you may want to reuse the cut off key head which houses the “chip” . It can often simply be attached to the ignition lock from behind where the factory security system can read it and bypass the factory system. If you damage the chip during cutting the key or prefer a wire in system, you can purchase a third party “Factory Security Bypass Module”

Once you choose the type of installation that fits your vehicle, use the information and wiring diagrams that follow to complete your connections.



*Refer to pg 15 for Accessory Power Outputs



Accessory
Harness
(See pg 15
for details)

Power
Harness #2

Power
Harness #1



Diagnostic
Port (Not Used)

Programming
Button

Start Button

Type 3:

Computerized or very modern motor & engine management system.

In the Type 3 configuration Accessory #1* & #2 turn off during starter cranking, but #2 is separately controlled by the first push of the Start Button when in "Accessory Mode". This circuit is designed for connecting any Accessories you would like to independently turn on while the vehicle is not running, such as the vehicles Radio or Video systems.

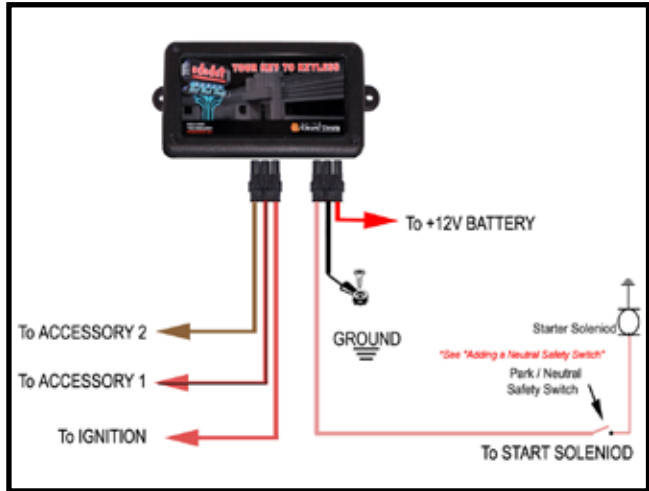

***Refer to pg 11 for Wire colors**

Accessory Power Outputs



AUX Accessory Output

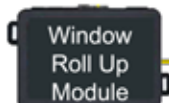

Or other Accessory

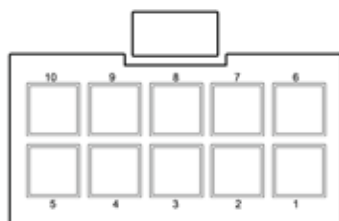

Viewed from Wire side of Plug
Deluxe Version Pin Out

- 1.) Blue Unlock Output (-)
- 2.) Green Lock Output (-)
- 3.) White Aux.1 Output (-)
- 4.) Yellow Aux.2 Output (-)
- 5.) Not Used
- 6.) Brown Brake Input (+)
- 7.) Not Used
- 8.) Red 12 Volt (+) Output
- 9.) Black (-) Ground Output
- 10.) Gray Parking Light Output (-)

PARKING LIGHT FLASHER

Connect to (-) Negative Parking Light Relay wire. If no relay is in vehicle one will need to be added.

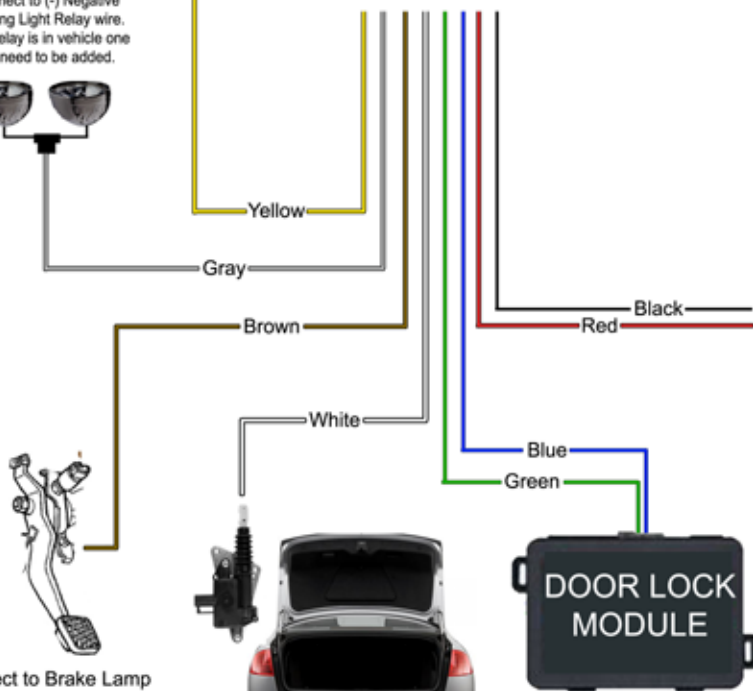

Connect to Brake Lamp Switch (+) or Clutch Switch (on Manual Transmissions). Wire should go to +12V when Brake is depressed.

Refer to pg 12 for "Accessory Harness" Plug location

EZ INSTALLATION *(For newer vehicles with locking steering columns)*

This installation is popular for newer cars with locking steering columns and hard to access ignition switches. It assumes you will be leaving a “Cut” key in the ignition switch and keeping it in the ON position. This will keep the steering column free and allows control of the ignition switch by cutting only the Ignition Feed wire and Start wire. This simple installation cuts just two wires and uses the existing Ignition switch to distribute power to all the vehicle systems except the start wire. Your Key to Keyless simply “controls” the power going to the switch and the starter.

- With Ignition Switch “OFF” test and locate the wire that supplies +12V to the Ignition Switch.
- Next, Turn the key to the “Start / Crank” position and test and locate the wire that gets hot during crank and supplies power to your starter solenoid.
- Remove your vehicles “Main” power fuse or disconnect power from the battery.
- Cut the +12V and Start /Crank wires and make connections as shown.
- Securely attach the systems Ground wire to a FACTORY CHASSIS GROUND
- Mount and connect the systems “Start Button”

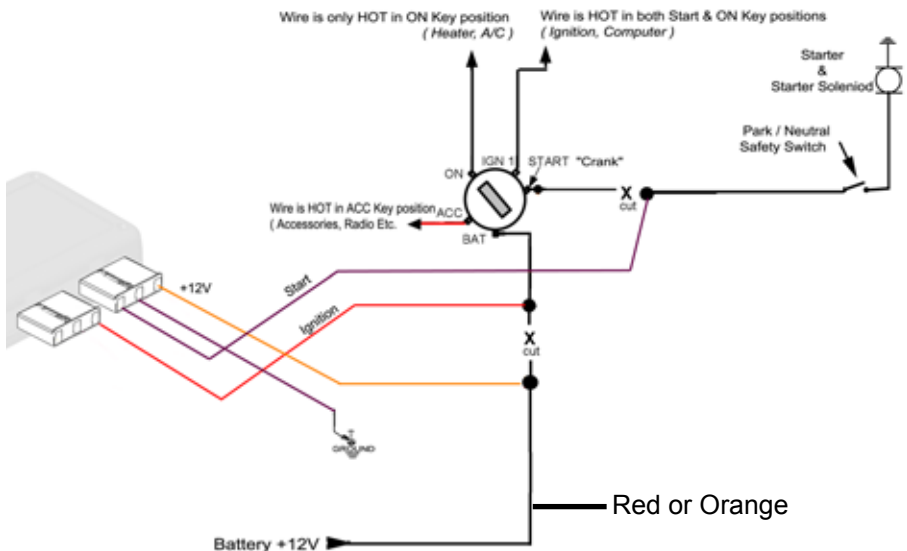

“Chip” in the key:

This method of installation also can provide a EZ solution to vehicles with a “Chip” in the key. After cutting the head off the key shaft, the head can usually be attached below or behind the Ignition switch where the factory anti-theft system will read it just as though it were in normal use.

IMPORTANT: It is critical that your Start / Crank wire is ran through a Neutral Safety Switch or Clutch Interlock Switch to protect the vehicle from accidentally moving during cranking of the starter. Use your vehicles existing switch or use the circuit below to add an safety switch to your vehicle.

Start / Crank Wire from Your Key to Keyless ICM

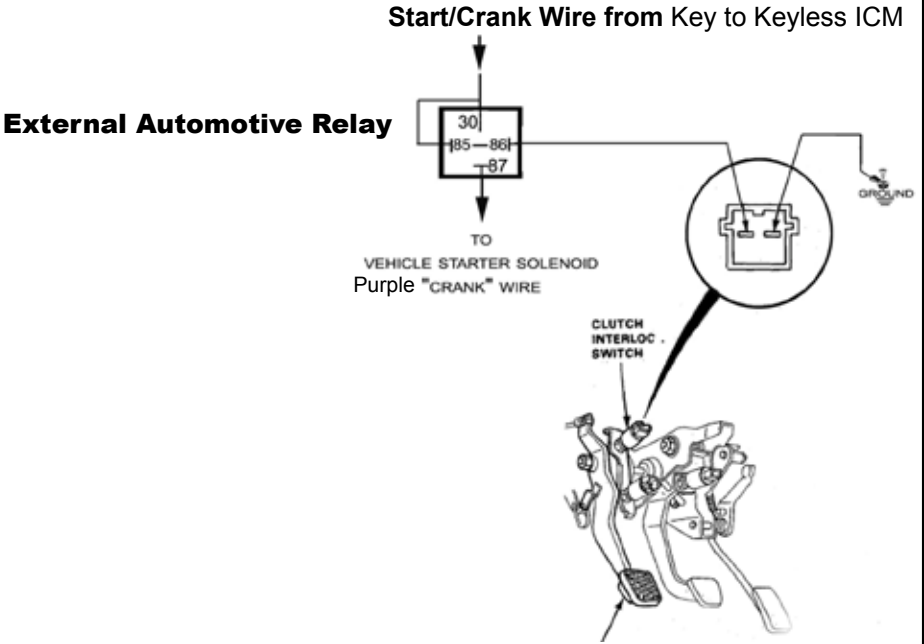

PUSH BUTTON SWITCH COUNSEL INSTALLATION:

The Push Button Switch can be mounted in any dash that is between 1/32" to 1/2" in thickness. The diameter of the hole that is needed for Push Button Switch is 7/8". When installing the switch into the dash use the nut to fasten it to the dash from the other end. Then by using the diagram below attach the wires into the plug accordingly and connect the plug to the ICM box. When installing the terminals into the connector, verify that the terminals are facing up (example shown below). Then simply push the wires into the connector until you hear them click.

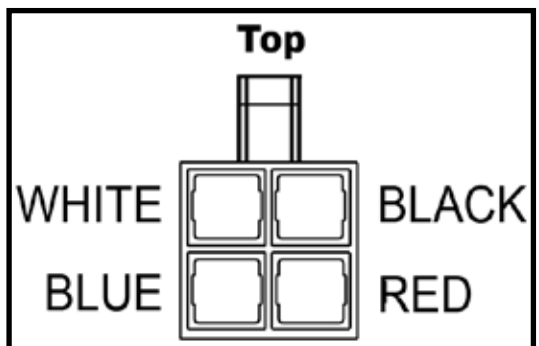

Diagram above shows back of plug (larger end).
This is the end to plug the terminals into.

TESTING THE SYSTEM:

Once you have completed your installation use the following instructions to test the system.

Initial testing is done with the Key FOB in **Manual mode**. In manual mode your proximity to the vehicle will not matter.

First test the Start button and Ignition system:

- ▶ Exit the vehicle and wait 60 seconds for the system to Arm.
- ▶ The LED in the Start button will go OFF, (* If Feature Select #4 is selected the button will flash)
- ▶ Depress the Unlock button on your Key FOB, this should authorize the system.
- ▶ Get in the vehicle and start your engine.

Assuming all went well, next test the automatic operation of the Key FOBs:

* If you have more than one Key FOB, test them one at a time. Complete a test of each Tag then proceed to the next.

- ▶ See: **Manual & Automatic Modes** earlier in this manual and find the instructions to put Key FOBs into Automatic mode.
- ▶ Switch your first Key FOB into automatic mode.
- ▶ Walk 50+ feet away from your vehicle and set the tag down.
- ▶ Walk back to your vehicle wait 60 seconds and confirm the Start Button LED is flashing.
- ▶ Enter and attempt to start the vehicle. ***It should not start.***
- ▶ Go back pick up your Key FOB and walk to the vehicle.
- ▶ Now get in and Start your engine!

PROGRAMMING MODES/FEATURE SELECT:

Feature Selection Mode

The KEY TO KEYLESS has a variety of selectable features to allow you to customize the systems operation to your individual needs: In the Feature Chart below, selectable features options are listed in the "Feature Column". Feature selection is made by setting the features "Position" to 1, 2 or 3.

	FEATURE	POSITION 1	POSITION 2	POSITION 3
1.	Starter Delay	N/A	N/A	N/A
2.	Door Lock Outputs	Single Pulse	Double Pulse	N/A
3.	Trunk Release/ Ch #3	Momentary	Latched	N/A
4.	Start Button LED	OFF when Armed	Flashing at Armed	N/A
5.	AUX Output/Ch #4	Latched	Momentary	N/A

To enter **Feature Select Mode**, first put system in **Accessory Mode**, by pressing the start button one time without putting your foot on the brake.

Next, then press the programming Button 5 times. *The LED should begin flashing fast then turn ON solid.*

Next, push the programming button the number of times equal to the feature you want to select

(Example: Push 4 times = Feature #4) the LED will flash back confirmation flashes the same number (4 times)

Next the LED will let you know what "Position" it is currently in by flashing either 1, 2 or 3 times

(All Features are by default set to #1)

To change the Features position setting; simply push and hold down the programming button for 1 second then release it. This will advance the feature to its next position. The LED will flash the corresponding number of times of the features new position. Pushing and holding again will return the feature to the original position.

When the selected feature indicates it in the desired position, momentarily depress the Brake.

The Start Buttons LED will begin flashing fast indicating the selection has been memorized, then the LED will return to solid ON awaiting the next feature selection. Change whichever features you desire in any order.

Once all features have been set to their desired positions, to exit Feature Select Mode, depress and HOLD the Brake down for a full 5 seconds until the Start Button LED begins a LONG fast flashing sequence indicating the system has exited Feature Select Mode.

Lastly, Push your Start Button 2 times to cycle out of ACC mode and return to Armed mode and your new features are now operable.

FEATURE SELECT OPTIONS:

FEATURE SELECT (F/S #1)

Starter Delay (Default setting = 0 seconds delay)

N/A

FEATURE SELECT (F/S #2)

Single / Double Pulse Door Lock Outputs (Default setting =Single Pulse)

Useful for vehicles that require a “Double Pulse” for unlocking or can be used to “Wake Up” the BCM on newer vehicles prior to door unlock.

FEATURE SELECT (F/S #3)

Trunk Release (Momentary or Latched) (Default setting = Momentary)

A “Long” push of the Unlock button of your Key FOB activates this channel. It Pulses or Latches a 500ma Negative. Although labeled “Trunk Release” this channel can be used for your choice of Accessory control.

F/S #3 toggles the output setting between Pulse and Latched.

FEATURE SELECT (F/S #4)

The **Start Button LED** (Default setting = OFF)

This feature selection allows you to select if you would like the Start Buttons LED to FLASH when the system is armed or remain OFF. The systems default setting is set to OFF when Armed. To make the LED FLASH WHEN THE SYSTEM IS ARMED use the feature Select directions to change F/S #4 to the second position.

FEATURE SELECT (F/S #5)

AUX Output (Default setting = Momentary)

This feature Select controls the output signal of the AUX Output. A “Long” push of the Lock button of your Key FOB activates this channel. It Pulses or Latches a 500ma Negative.

F/S #5 toggles the output setting between Pulse and Latched.

STILL CAN'T GET IT?

ididit inc. has been serving the rodding community for over 25 years and one of the major factors has always been our excellent customer service. If you still can't get it and you have tried everything on these pages feel free to call us at (517) 424-0577, Monday-Friday from 8:30a-5:30p and Sat. 10:00a-2:00p Eastern Standard Time. You can also email us at tech@ididitinc.com

Warranty Statement

The **Key to Keyless** Intelligent Push Button Start System from ididit/Digital Guard Dawg, Inc is guaranteed to be free from defects in material and/or workmanship and to perform as advertised for a period of 1 year from date of purchase when properly installed, used and maintained in accordance with the installation instructions. Failure to adhere to and/or comply with the installation instructions will void all associated warranty obligations. Should any part(s) prove defective within 1 year from date of purchase, it(they) will be replaced F.O.B. our factory without charge provided the defective part(s) is returned to our factory.

ididit/Digital Guard Dawg, Inc is not responsible for labor charges, loss or consequential damage of any kind or character caused by defected parts or charges incurred in the replacement or repair of defective parts by the Purchaser. Careless handling, including that by freight companies, and improper installation or use may void all warranties.

Question or comments regarding this product or it's warranty can be sent to:

Digital Guard Dawg, Inc.
705 E. Bidwell St
Suite 2325
Folsom, CA 95630
877-246-5395
WWW.2GOKEYLESS.COM

ididit incorporated
610 S. Maumee St.
Tecumseh, MI 49286
517-424-0577
www.ididitinc.com

No part of this guide may be reprinted, reproduced or utilized in any form without the express written permission of ididit, inc.

2011 ididit, inc.
All Rights Reserved
Printed in the USA

ididit, inc.
610 S. Maumee St., Tecumseh, MI 49286
(517) 424-0577 • (517) 424-7293 fax
www.ididitinc.com